

Compressivi girevoli con freno Serie 75/2LFT nelle varie tipologie di: Fissaggi, Ruote assemblati
 Swivel castors with brake of the 75/2LFT series with different types of fixings, assembled wheels

Requisiti dei Compressivi assemblati alle varie Ruote Requirements of the castors assembled with the different wheels	G	Gd	-	-	-	-	-	N
Portata Dinamica conforme UNI EN 12527 Dynamic load capacity conform UNI EN 12527		D	-	-	-	-	-	-
Portata Statica conforme UNI EN 12527 Static load capacity conform UNI EN 12527		S	-	-	-	-	-	-
Resistenza Passiva del Dispositivo Frenante Conforme UNI EN 12527 Passive resistance of braking device in compliance with UNI EN 12527		FT	-	-	-	-	-	-

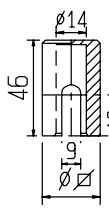
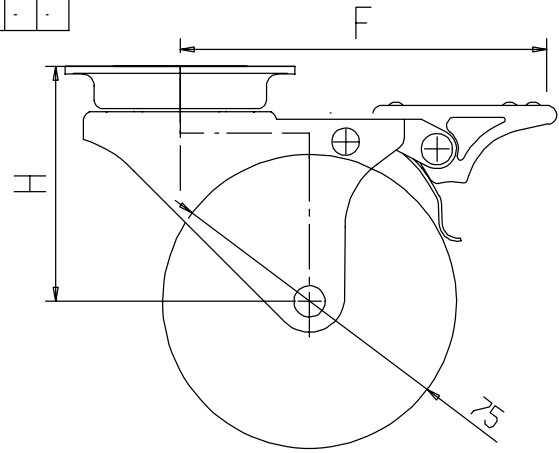
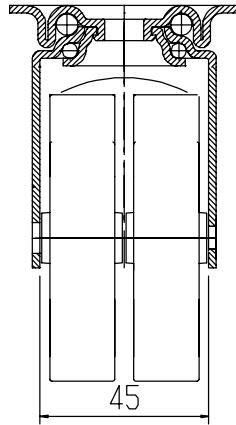

Adattatori
adaptors

∅	18	19	22	25	28
∅	21	26	31		

ITEM		code	Rondella Washer	B10 ∅10.2 a Richiesta On request	F	C+ Adattatori adaptors	PI 60x60	P3 77x67	P7 68.5x48
8123	5		0						
			= Peso per 1 pezzo = Weight for a piece						
75LGx2		ITEM	75/2LFT/G0	75/2LFT/GB10	75/2LFT/GF	75/2LFT/GC	75/2LFT/GPI	75/2LFT/GP3	75/2LFT/GP7
			-	-	-	-	-	-	-
		code	1755						
75LGdx2		ITEM	75/2LFT/Gd0	75/2LFT/GdB10	75/2LFT/GdF	75/2LFT/GdC	75/2LFT/GdPI	75/2LFT/GdP3	75/2LFT/GdP7
			-	-	-	-	-	-	-
		code							
75LNx2		ITEM	75/2LFT/N0	75/2LFT/NB10	75/2LFT/NF	75/2LFT/NC	75/2LFT/NPI	75/2LFT/NP3	75/2LFT/NP7
			-	-	-	-	-	-	-
		code	1790	1791	1792			1794	
ITEM	75/2LFT/G-Gd con Asse Rivettato With riveted axle		ITEM	75/2LFT/N con Asse a Vite With screw axle		ITEM	75/2LFT/G-Gd Nucleo Grigio Grey Centre		

Compressivi girevoli con freno Serie 50/2FT nelle varie tipologie di: Fissaggi, Ruote assemblati
 Swivel castors with brake of the 50/2FT series with different types of fixings, assembled wheels

Requisiti dei Compressivi assemblati alle varie Ruote Requirements of the castors assembled with the different wheels	G	Gd	Gc	GA	GcA	SR	SRd	N
Portata Dinamica conforme UNI EN 12527 Dynamic load capacity conform UNI EN 12527	D	60	60	60	-	-	-	35
Portata Statica conforme UNI EN 12527 Static load capacity conform UNI EN 12527	S	90	90	90	-	-	-	52
Resistenza Passiva del Dispositivo Frenante Conforme UNI EN 12527 Passive resistance of braking device Conform UNI EN 12527	FT	-	-	-	-	-	-	-
Conducibilit�Elettrica conforme UNI EN 12527 Electric conductivity in compliance with UNI EN 12527	hom				< 10.000			

* Gli articoli evidenziati in colore verde sono in fase di allestimento.
 * Articles written in green colour are in course of preparation

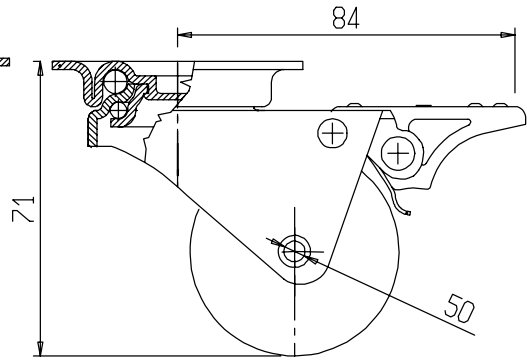
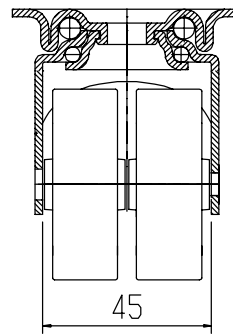
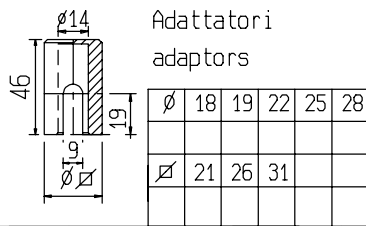

ITEM		code	Rondella Washer	B10 ∅10.2 a Richiesta On request	F	C+Adattatori adaptors	PI 60x60	P3 77x67	P7 68.5x48
8123	5								
			0	∅12.2	∅10.2				
50LGx2		ITEM	50/2FT/G0	50/2FT/GB10	50/2FT/GF	50/2FT/GC	50/2FT/GPI	50/2FT/GP3	50/2FT/GP7
			304	311	330	367	351	367	348
		code	1720	1807	1722		1723		
50LGdx2		ITEM	50/2FT/Gd0	50/2FT/GdB10	50/2FT/GdF	50/2FT/GdC	50/2FT/GdPI	50/2FT/GdP3	50/2FT/GdP7
			312	319	338	375	367	383	364
		code	1730	1731	1732		1733		
50LGcx2		ITEM	50/2FT/Gc0	50/2FT/GcB10	50/2FT/GcF	50/2FT/GcC	50/2FT/GcPI	50/2FT/GcP3	50/2FT/GcP7
			373	380	399	436	420	436	417
		code	1740	1799			1743		
50LGAx2		ITEM	50/2FT/GA0	50/2FT/GAB10	50/2FT/GAF	50/2FT/GAC	50/2FT/GAPI	50/2FT/GAP3	50/2FT/GAP7
			-	-	-	-	-	-	-
50LGCx2		ITEM	50/2FT/GcA0	50/2FT/GcAB10	50/2FT/GcAF	50/2FT/GcAC	50/2FT/GcAPI	50/2FT/GcAP3	50/2FT/GcAP7
			-	-	-	-	-	-	-
code									
50LSRx2		ITEM	50/2FT/SR0	50/2FT/SRB10	50/2FT/SRF	50/2FT/SRC	50/2FT/SRPI	50/2FT/SRP3	50/2FT/SRP7
			279	286	305	342	326	342	323
		code							
50LSRdx2		ITEM	50/2FT/SRd0	50/2FT/SRdB10	50/2FT/SRdF	50/2FT/SRdC	50/2FT/SRdPI	50/2FT/SRdP3	50/2FT/SRdP7
			270	277	296	333	325	341	322
		code							
50LNx2		ITEM	50/2FT/N0	50/2FT/NB10	50/2FT/NF	50/2FT/NC	50/2FT/NPI	50/2FT/NP3	50/2FT/NP7
			246	253	263	309	293	309	290
		code	1750	1724	1752		1817		
ITEM	50/2FT/G-Gd-GA-SR-SRd	ITEM	50/2FT/N			ITEM	50/2FT/G-Gd-Gc		
	con Asse Rivettato with riveted axle		con Asse a Vite With screw axle				Nucleo Grigio Grey Centre		
	-								